

Vaulting

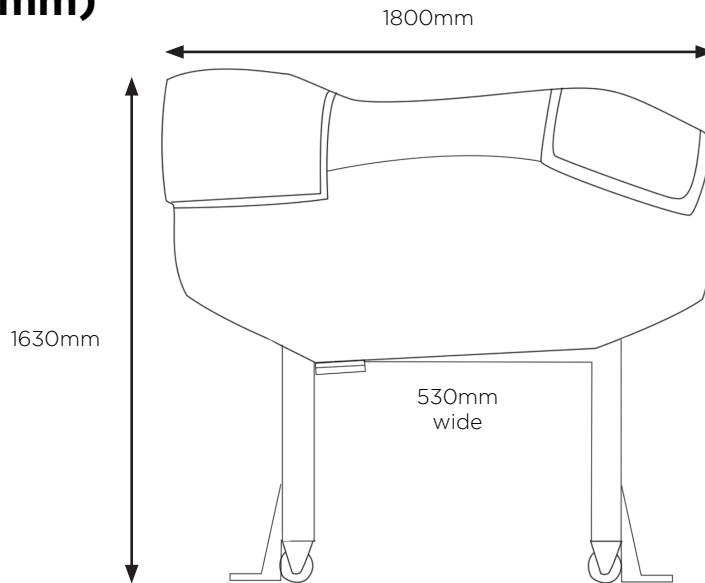

Dimensions (mm)



Standard features

Variable speed smooth and realistic canter action with lateral movement. Girth attachment for ES Vario 2000 surcingle. Grip spray over the back, leather grip pad on neck and rump and 4 wheels for easy manoeuvring.

Required door width and ceiling height

The simulator can't easily be moved up or down steps or bend in the middle, please consider this when you are planning the location of your simulator. Minimum door width of 700mm and ceiling height of 3000mm required.

Floor fixing

Smooth level concrete floor recommended
2 expansion bolts drilled into floor at the front of the horse and 2 expansion bolt drilled into the floor at the rear of the horse. This simulator must be bolted to the floor prior to use. Please let us know if you are unable to fix your machine to your floor or you have underfloor heating.

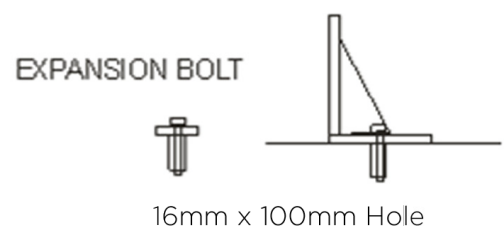

Power requirements

Any standard EU power socket . 1 x 210 - 230v UK plug socket, 50 - 60 Hz, 8 amps. A residual current device (RCD) or an Earth Leakage Circuit Breaker must be installed in the electrical distribution system.

Location and environment

Dry, dust free environment, with no extreme variations in temperature.