

Dressage

Dimensions (mm)

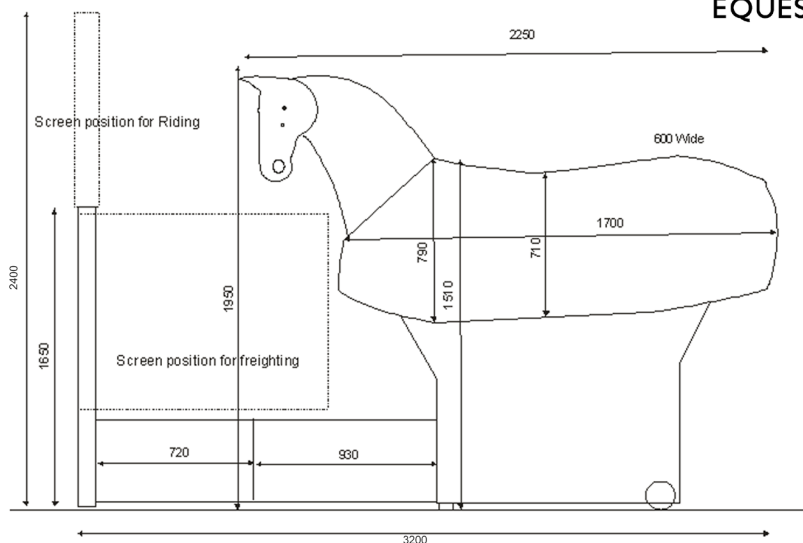

Standard features

Our most popular simulator. This machine accommodates riders of all levels from beginners to advanced. Allowing you to practise advanced dressage movements such as: Piaffe, Passage and Half Pass along with arena work and test practice. A revolutionary way to focus on interaction, skills and balance by viewing immediate visual feedback on seat position, rein pressure and riding movements. TV, mounting block, bridle and reins included as standard.

Optional additions

Stabilising bar - for when the simulator can't be fixed to the floor.

Trolley - if you intend on moving the simulator in the future.

Saddle - Dressage saddle fitted to work accurately with the sensors.

Required door width and ceiling height

The simulator can not easily be moved up or down steps and will not bend in the middle, please consider this when you are planning the location of your simulator. Minimum door width of 700mm and a minimum ceiling height of 2800mm required.

Floor fixing

Smooth level concrete floor recommended
2 expansion bolts drilled into floor at the front of the horse and 2 expansion bolts drilled into the floor through the TV frame. This simulator must be bolted to the floor prior to use if a stabilising bar is not used.

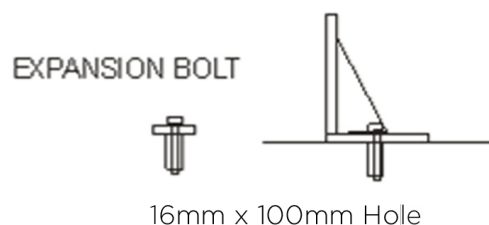

Power requirements

1 x 210 - 230v UK plug socket, 50 - 60 Hz, 8 amps. A residual current device (RCD) or an Earth Leakage Circuit Breaker must be installed in the electrical distribution system.

Location and environment

Dry, dust free environment, with no extreme variations in temperature.

Registered Office 15a Park Road Tarporley Cheshire Registered In England and Wales number 2901930. VAT No. GB 666 5574 91

info@racewood.com www.racewood.com +44 (0)1829 732 006

MADE IN BRITAIN